



Business Report by the FSC Board of Directors for 2005 - 2008



Board Members



Chamber	2006	2007	2008
Environmental	Grant Rosoman	Grant Rosoman	Kouami Kokou
	Cristian Vallejos	Cristian Vallejos	Cristian Vallejos
	Eric Palola	Eric Palola	Eric Palola
Social	Martha Nunez	Martha Nunez	Jaime Levy
	Chris v Dam	Chris v Dam	Luis Astorga
	Chris vd Goot	Chris vd Goot	Chris vd Goot
Economic	Shaun McCartney	Roberto Waack	Roberto Waack
	Victor Giraldo	Mario Abreu	Mario Abreu
15	Asa Tham	Alan Knight	Alan Knight

Meetings

2006	2007	2008
Bonn	Bonn	Bonn
St Petersburg	Beijing	Bonn
Bonn	Bonn	Cape Town

Executive Committee conference calls, in average, every two weeks

Committees

- Executive
- Membership Committee
- National Standards Accreditation Committee
- Certification Bodies Accreditation Committee
- National Initiatives Accreditation Committee
- Policy and Standards Committee
- Finance Committee
- Governance Review Committee
- Pesticides Committee
- Representative for FSC at the FSC Global Fund
- ED Recruitment Committee
- General Assembly 2008 Committee
- Motions Committee for General Assembly 2008

The FSC Global Strategy

- **Leadership** in responsible forest management;
- Ensure **equitable access** to the benefits of FSC;
- Secure the **integrity, credibility and transparency**;
- Create more **business value** than products from non-certified forests;
- **Strengthen our global network** to deliver these goals

Action fields

- Recognizing and addressing the importance of the roots...NIs, network reconnection
- Global Development Company, trade mark management and value creation
- Reinforcing the Accreditation and Certification schemes
- New financial tools ... external Finance Committee, audits, budgeting, rolling forecasts
- Social strategy
- Governance review

November 3–7
2008

www.fsc.org

Transition

- Heiko Leadeker leaving
- Andre de Freitas taking the lead

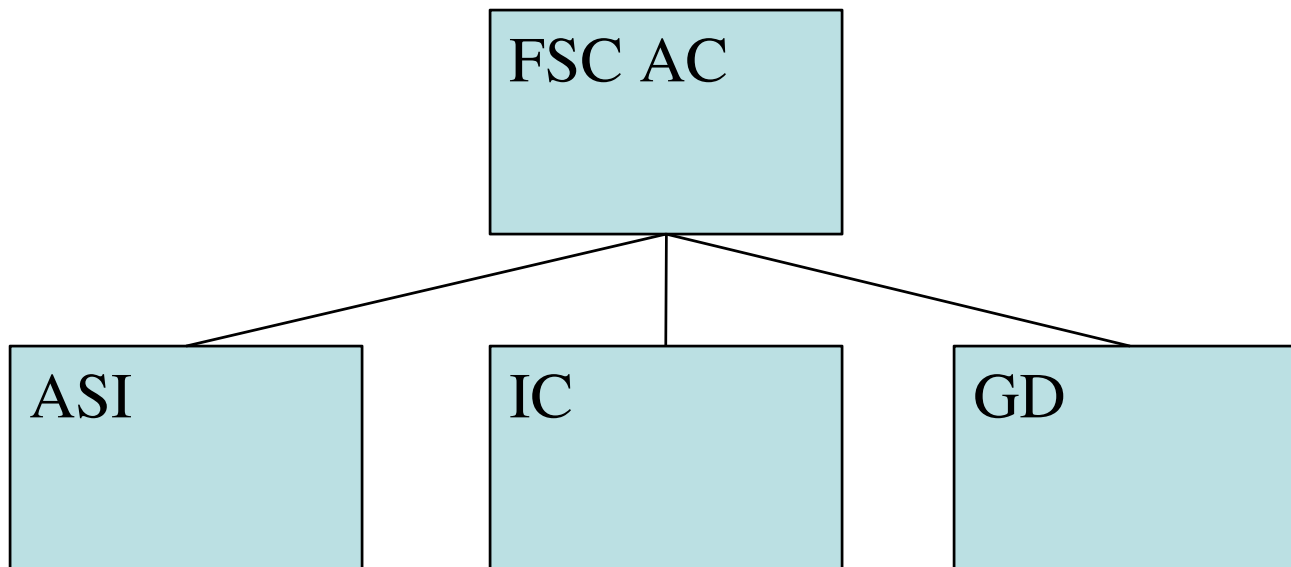

Forest arena changing

- Carbon ... metrics and methodologies, financial architectures, distribution of wealth
- Other environmental services...water, rain cycle, biodiversity
- Food safety, land use, land rights
- Bioenergy, charcoal, cellulosic “tree”thanol
- New technologies...satellite image, digital tagging...
- Financial schemes for forests ...”not a correlated asset, with benchmarking of 8% with 12% vol.”
- SRIs – Social Responsible Investments, risk management, reputational risks, moral liability...
- Growing complexity of chain transactions
- Sophistication of customers perception and management of Sustainability...Branding...Greenwashing
- New multistakeholders schemes emulating FSC

The FSC Global Strategy

- **Leadership** in responsible forest management;
- Ensure **equitable access** to the benefits of FSC;
- Secure the **integrity, credibility and transparency**;
- Create more **business value** than products from non-certified forests;
- **Strengthen our global network** to deliver these goals

The FSC Global Strategy

- Leadership in responsible forest management:
 - The North
- Ensure equitable access to the benefits of FSC:
 - The choices we made!
- Secure the chain of custody and transparency:
 - Monitor the implementation
- Create more business value than products from non-certified sources:
 - Transparent indicators
- Strengthen our global network to deliver these goals

The FSC Global Strategy

A strategic oriented Board committed to:

- ✓ Open and transparent negotiation
- ✓ Struggling to always get to consensus
- ✓ Having “one voice”

Obrigado



November 3–7
2008
www.fsc.org